

# JV50-MV DDR2 M92 Block Diagram

Project code: 91.40001.001  
 PCB P/N : 48.40004.00A  
 REVISION : 0001-0A

## Diagram

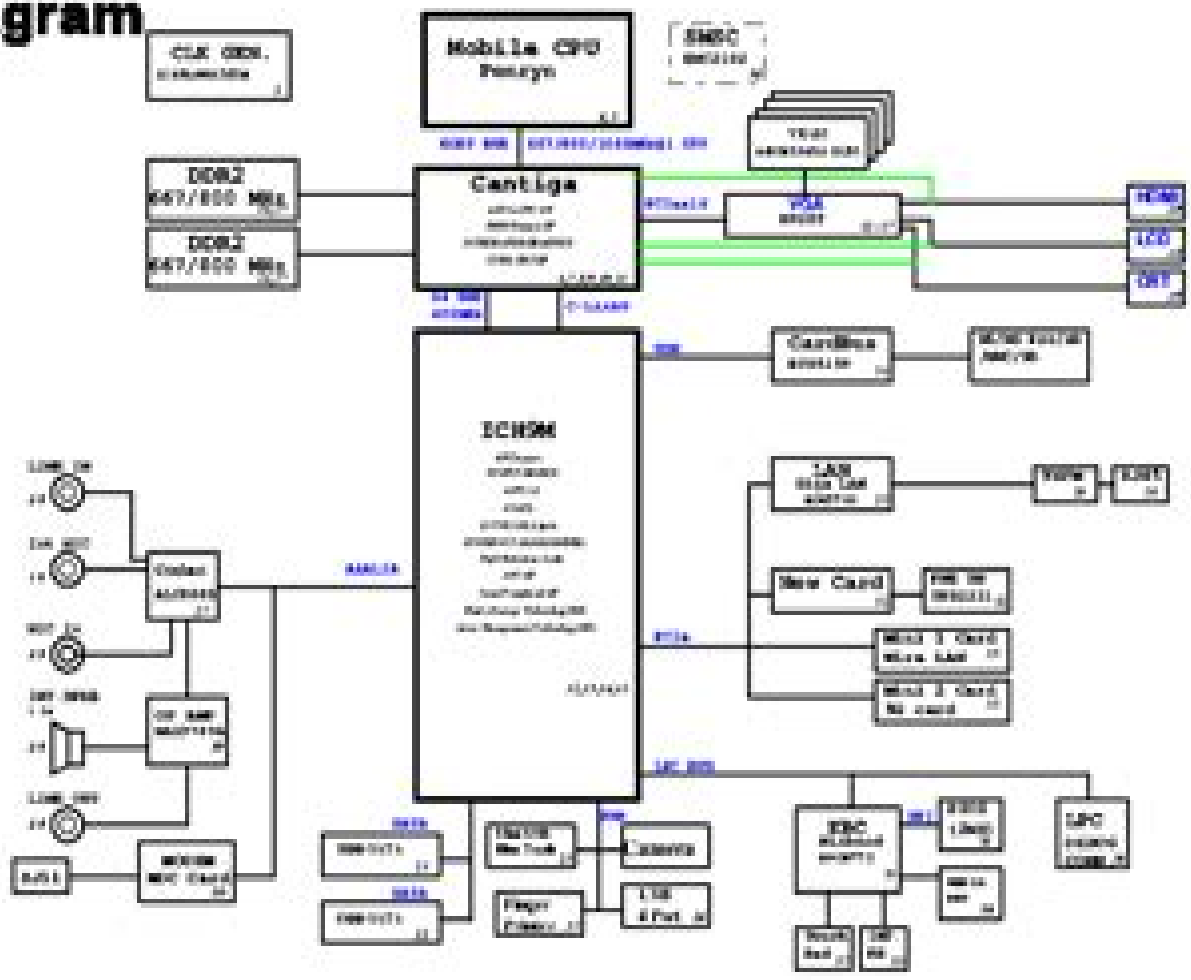

REV. HISTORY

REV.	DESCRIPTION	DATE
001	INITIAL	01/01/01
002	...	...
003	...	...
004	...	...
005	...	...
006	...	...
007	...	...
008	...	...
009	...	...
010	...	...

SYSTEM BOARD	
REV.	DESCRIPTION
001	INITIAL
002	...
003	...
004	...
005	...
006	...
007	...
008	...
009	...
010	...
011	...
012	...
013	...
014	...
015	...
016	...
017	...
018	...
019	...
020	...
021	...
022	...
023	...
024	...
025	...
026	...
027	...
028	...
029	...
030	...
031	...
032	...
033	...
034	...
035	...
036	...
037	...
038	...
039	...
040	...
041	...
042	...
043	...
044	...
045	...
046	...
047	...
048	...
049	...
050	...
051	...
052	...
053	...
054	...
055	...
056	...
057	...
058	...
059	...
060	...
061	...
062	...
063	...
064	...
065	...
066	...
067	...
068	...
069	...
070	...
071	...
072	...
073	...
074	...
075	...
076	...
077	...
078	...
079	...
080	...
081	...
082	...
083	...
084	...
085	...
086	...
087	...
088	...
089	...
090	...
091	...
092	...
093	...
094	...
095	...
096	...
097	...
098	...
099	...
100	...

# Acer Jv50 Manual

**Hongru Du**



## **Acer Jv50 Manual:**

Discover tales of courage and bravery in its empowering ebook, Stories of Fearlessness: **Acer Jv50 Manual** . In a downloadable PDF format (\*), this collection inspires and motivates. Download now to witness the indomitable spirit of those who dared to be brave.

[https://learningcenter.csa.ca/files/book-search/fetch.php/alphabet\\_letters\\_and\\_matching\\_picture\\_print\\_out.pdf](https://learningcenter.csa.ca/files/book-search/fetch.php/alphabet_letters_and_matching_picture_print_out.pdf)

## **Table of Contents Acer Jv50 Manual**

1. Understanding the eBook Acer Jv50 Manual
  - The Rise of Digital Reading Acer Jv50 Manual
  - Advantages of eBooks Over Traditional Books
2. Identifying Acer Jv50 Manual
  - Exploring Different Genres
  - Considering Fiction vs. Non-Fiction
  - Determining Your Reading Goals
3. Choosing the Right eBook Platform
  - Popular eBook Platforms
  - Features to Look for in an Acer Jv50 Manual
  - User-Friendly Interface
4. Exploring eBook Recommendations from Acer Jv50 Manual
  - Personalized Recommendations
  - Acer Jv50 Manual User Reviews and Ratings
  - Acer Jv50 Manual and Bestseller Lists
5. Accessing Acer Jv50 Manual Free and Paid eBooks
  - Acer Jv50 Manual Public Domain eBooks
  - Acer Jv50 Manual eBook Subscription Services
  - Acer Jv50 Manual Budget-Friendly Options
6. Navigating Acer Jv50 Manual eBook Formats

- ePub, PDF, MOBI, and More
  - Acer Jv50 Manual Compatibility with Devices
  - Acer Jv50 Manual Enhanced eBook Features
7. Enhancing Your Reading Experience
    - Adjustable Fonts and Text Sizes of Acer Jv50 Manual
    - Highlighting and Note-Taking Acer Jv50 Manual
    - Interactive Elements Acer Jv50 Manual
  8. Staying Engaged with Acer Jv50 Manual
    - Joining Online Reading Communities
    - Participating in Virtual Book Clubs
    - Following Authors and Publishers Acer Jv50 Manual
  9. Balancing eBooks and Physical Books Acer Jv50 Manual
    - Benefits of a Digital Library
    - Creating a Diverse Reading Collection Acer Jv50 Manual
  10. Overcoming Reading Challenges
    - Dealing with Digital Eye Strain
    - Minimizing Distractions
    - Managing Screen Time
  11. Cultivating a Reading Routine Acer Jv50 Manual
    - Setting Reading Goals Acer Jv50 Manual
    - Carving Out Dedicated Reading Time
  12. Sourcing Reliable Information of Acer Jv50 Manual
    - Fact-Checking eBook Content of Acer Jv50 Manual
    - Distinguishing Credible Sources
  13. Promoting Lifelong Learning
    - Utilizing eBooks for Skill Development
    - Exploring Educational eBooks
  14. Embracing eBook Trends
    - Integration of Multimedia Elements
    - Interactive and Gamified eBooks

## Acer Jv50 Manual Introduction

In the digital age, access to information has become easier than ever before. The ability to download Acer Jv50 Manual has revolutionized the way we consume written content. Whether you are a student looking for course material, an avid reader searching for your next favorite book, or a professional seeking research papers, the option to download Acer Jv50 Manual has opened up a world of possibilities. Downloading Acer Jv50 Manual provides numerous advantages over physical copies of books and documents. Firstly, it is incredibly convenient. Gone are the days of carrying around heavy textbooks or bulky folders filled with papers. With the click of a button, you can gain immediate access to valuable resources on any device. This convenience allows for efficient studying, researching, and reading on the go. Moreover, the cost-effective nature of downloading Acer Jv50 Manual has democratized knowledge. Traditional books and academic journals can be expensive, making it difficult for individuals with limited financial resources to access information. By offering free PDF downloads, publishers and authors are enabling a wider audience to benefit from their work. This inclusivity promotes equal opportunities for learning and personal growth. There are numerous websites and platforms where individuals can download Acer Jv50 Manual. These websites range from academic databases offering research papers and journals to online libraries with an expansive collection of books from various genres. Many authors and publishers also upload their work to specific websites, granting readers access to their content without any charge. These platforms not only provide access to existing literature but also serve as an excellent platform for undiscovered authors to share their work with the world. However, it is essential to be cautious while downloading Acer Jv50 Manual. Some websites may offer pirated or illegally obtained copies of copyrighted material. Engaging in such activities not only violates copyright laws but also undermines the efforts of authors, publishers, and researchers. To ensure ethical downloading, it is advisable to utilize reputable websites that prioritize the legal distribution of content. When downloading Acer Jv50 Manual, users should also consider the potential security risks associated with online platforms. Malicious actors may exploit vulnerabilities in unprotected websites to distribute malware or steal personal information. To protect themselves, individuals should ensure their devices have reliable antivirus software installed and validate the legitimacy of the websites they are downloading from. In conclusion, the ability to download Acer Jv50 Manual has transformed the way we access information. With the convenience, cost-effectiveness, and accessibility it offers, free PDF downloads have become a popular choice for students, researchers, and book lovers worldwide. However, it is crucial to engage in ethical downloading practices and prioritize personal security when utilizing online platforms. By doing so, individuals can make the most of the vast array of free PDF resources available and embark on a journey of continuous learning and intellectual growth.

## FAQs About Acer Jv50 Manual Books

**What is a Acer Jv50 Manual PDF?** A PDF (Portable Document Format) is a file format developed by Adobe that preserves the layout and formatting of a document, regardless of the software, hardware, or operating system used to view or print it.

**How do I create a Acer Jv50 Manual PDF?** There are several ways to create a PDF: Use software like Adobe Acrobat, Microsoft Word, or Google Docs, which often have built-in PDF creation tools. Print to PDF: Many applications and operating systems have a "Print to PDF" option that allows you to save a document as a PDF file instead of printing it on paper. Online converters: There are various online tools that can convert different file types to PDF.

**How do I edit a Acer Jv50 Manual PDF?** Editing a PDF can be done with software like Adobe Acrobat, which allows direct editing of text, images, and other elements within the PDF. Some free tools, like PDFescape or Smallpdf, also offer basic editing capabilities.

**How do I convert a Acer Jv50 Manual PDF to another file format?** There are multiple ways to convert a PDF to another format: Use online converters like Smallpdf, Zamzar, or Adobe Acrobats export feature to convert PDFs to formats like Word, Excel, JPEG, etc. Software like Adobe Acrobat, Microsoft Word, or other PDF editors may have options to export or save PDFs in different formats.

**How do I password-protect a Acer Jv50 Manual PDF?** Most PDF editing software allows you to add password protection. In Adobe Acrobat, for instance, you can go to "File" -> "Properties" -> "Security" to set a password to restrict access or editing capabilities. Are there any free alternatives to Adobe Acrobat for working with PDFs? Yes, there are many free alternatives for working with PDFs, such as: LibreOffice: Offers PDF editing features. PDFsam: Allows splitting, merging, and editing PDFs. Foxit Reader: Provides basic PDF viewing and editing capabilities. How do I compress a PDF file?

You can use online tools like Smallpdf, ILovePDF, or desktop software like Adobe Acrobat to compress PDF files without significant quality loss. Compression reduces the file size, making it easier to share and download. Can I fill out forms in a PDF file? Yes, most PDF viewers/editors like Adobe Acrobat, Preview (on Mac), or various online tools allow you to fill out forms in PDF files by selecting text fields and entering information. Are there any restrictions when working with PDFs?

Some PDFs might have restrictions set by their creator, such as password protection, editing restrictions, or print restrictions. Breaking these restrictions might require specific software or tools, which may or may not be legal depending on the circumstances and local laws.

## Find Acer Jv50 Manual :

**alphabet letters and matching picture print out**

[alternate edition for economics](#)

*allis chalmers g service manual*

[allison mt643 manual](#)

**allis chalmers wc manuals**

[almera 02 workshop manual](#)

**alte meister eisenbahn fotografie karl ernst maedel**

[altec at200 manual](#)

**alles over potloden en hoe je daarmee tekent**

[alliance apu service manual](#)

[allison 250 series ii service manual](#)

[alone with the horrors the great short fiction of ramsey campbell 1961 1991](#)

[allis chalmers wd repair manual](#)

**alpern boll developmental profile manual**

[als breekbaar kristal](#)

**Acer Jv50 Manual :**

[renaissance and reformation test form b qa nuevesolutions](#) - Jan 12 2022

web right here we have countless books renaissance and reformation test form b and collections to check out we additionally present variant types and with type of the books to browse

[renaissance reformation enlightenment chapter exam](#) - Dec 23 2022

web test prep courses praxis citizenship education content knowledge 5087 prep course renaissance reformation enlightenment chapter renaissance reformation enlightenment chapter exam free

**renaissance reformation test 1 flashcards quizlet** - Nov 21 2022

web renaissance reformation test 1 anne boleyne click the card to flip 2nd wife of henry viii she was his first wife s lady in waiting had a daughter w henry elizabeth i later she was beheaded click the card to flip

[renaissance and reformation questions for tests and worksheets](#) - Jul 30 2023

web renaissance and reformation questions all grades you can create printable tests and worksheets from these renaissance and reformation questions select one or more questions using the checkboxes above each question

**renaissance and reformation chapter test form a** - Sep 19 2022

web title microsoft word hl08 sur pas 000 tcp doc author cbowlin created date 3 26 2007 3 10 05 pm

**winston salem forsyth county schools front page** - Jan 24 2023

web renaissance and reformation test part i matching 1 seculara to improve as by correction errors or removing defects 2



taxationb connected to god gods or having a connection to religion 3 reformc dishonesty or improper behavior especially in a person in power 4 corruptiond not pertaining to or connected to religion

**renaissanceandreformationtestformb download only** - Oct 21 2022

web middle ages renaissance and reformation history the renaissance the protestant revolution and the catholic reformation in continental europe classic reprint renaissance and reformation the church of the renaissance and reformation renaissance and reformation renaissance and reform in tudor england the

**renaissance and reformation test form b pdf pdf** - May 16 2022

web may 7 2023 in some cases you likewise attain not discover the proclamation renaissance and reformation test form b pdf that you are looking for it will enormously squander the time however below as soon as you visit this web page it will be fittingly completely easy to get as well as download guide renaissance and

*renaissance and reformation chapter test form b* - Aug 31 2023

web renaissance 2 how did humanism change the way people thought 3 describe three ways that the ideas of the italian renaissance spread to the north 4 describe how the council of trent impacted catholicism 5 compare and contrast the ideals of girolamo savonarola and ignatius of loyola practicing social studies skills study the

**test form b renaissance and reformation pdf uniport edu** - Mar 14 2022

web apr 8 2023 this online pronouncement test form b renaissance and reformation can be one of the options to accompany you subsequently having extra time it will not waste your time say yes me the e book will definitely flavor you new event to read just invest tiny era to entre this on line pronouncement test form b renaissance and reformation as

*renaissance and reformation test form b uniport edu* - Feb 10 2022

web you could buy guide renaissance and reformation test form b or acquire it as soon as feasible you could speedily download this renaissance and reformation test form b after getting deal

**renaissance and reformation test study guide flashcards** - Mar 26 2023

web study with quizlet and memorize flashcards containing terms like renaissance florence medici family and more

**renaissance and reformation test form b** - May 28 2023

web thank you for downloading renaissance and reformation test form b as you may know people have search numerous times for their chosen novels like this renaissance and reformation test form b but end up in infectious downloads rather than reading a good book with a cup of tea in the afternoon instead they cope with some infectious bugs

renaissance and reformation chapter test form b 2023 - Apr 26 2023

web stir emotions provoke thought and instigate transformation is really remarkable this extraordinary book aptly titled renaissance and reformation chapter test form b published by a very acclaimed author immerses readers in a captivating

exploration of the significance of language and its profound affect our existence

[the renaissance and reformation unit test flashcards](#) - Feb 22 2023

web study with quizlet and memorize flashcards containing terms like which phenomenon contributed to the renewal of interest in classical philosophy and arts use the quotation to answer the question how did renaissance humanism promote secularism and more

**renaissance and reformation chapter test form b pdf** - Jun 16 2022

web feb 4 2023 renaissance and reformation chapter test form b 1 1 downloaded from las gnome org on february 4 2023 by guest renaissance and reformation chapter test form b this is likewise one of the factors by obtaining the soft documents of this renaissance and reformation chapter test form b by online

**test form b renaissance and reformation pdf uniport edu** - Aug 19 2022

web may 1 2023 test form b renaissance and reformation 1 5 downloaded from uniport edu ng on may 1 2023 by guest test form b renaissance and reformation thank you for downloading test form b renaissance and reformation as you may know people have search numerous times for their chosen books like this test form b

**text of renaissance and reformation test** - Jul 18 2022

web renaissance and reformation test instructions you don t need to print off this test to turn back in use your own paper to write your answers down on include the short answer and essay questions there are 27 questions on the test but you may select to answer either 21 or 22 on your answer key you don t need to write an essay just an

[test the renaissance and reformation flashcards quizlet](#) - Jun 28 2023

web study with quizlet and memorize flashcards containing terms like members of an important family of kings in england were called a dispute between the english and the french over the french throne was known as the french calvinists were called and more

**free renaissance and reformation test form b** - Apr 14 2022

web renaissance and reformation test form b pdf renaissance and reformation test form b 2 downloaded from analytics test makestories io on by guest weaknesses subject reviews that include test tips and chapter end quizzes full length model practice exam with answers and explanations a history of western music donald jay grout

**60 free praxis practice tests to prepare for the exam** - Aug 18 2023

web may 16 2023 praxis special education 5354 practice test praxis special education 5372 practice test praxis special education 5543 practice test praxis special education 5691 practice test praxis special ed 5383 teaching students with learning disabilities other praxis practice tests principles of learning and teaching

[practice tests for praxis ii 5856 download only](#) - Jul 17 2023

web praxis ii middle school science practice questions praxis ii practice tests and exam review for the praxis ii subject assessments apex test prep praxis ii social studies practice questions are the simplest way to prepare for your praxis ii test practice is an essential part of preparing for a test and improving a test taker s chance of success

[practice test for praxis 5856 knockinc com](#) - Jun 04 2022

web jan 6 2023 4728788 practice test for praxis 5856 1 30 downloaded from knockinc com on by guest practice test for praxis 5856 as recognized adventure as with ease as experience very nearly lesson amusement as capably as concurrence can be gotten by just checking out a book practice test for praxis 5856 plus it is not

[practice tests for praxis ii 5856 pdf uniport edu](#) - Oct 08 2022

web jul 20 2023 getting this info acquire the practice tests for praxis ii 5856 connect that we manage to pay for here and check out the link you could buy lead practice tests for praxis ii 5856 or acquire it as soon as feasible you could speedily download this practice tests for praxis ii 5856 after getting deal

[read book practice test for praxis 5856 free download pdf](#) - Feb 12 2023

web read book practice test for praxis 5856 free download pdf praxis core praxis core test prep intermediate vocabulary 2 4 practice tests and praxis core academic skills for educators exam prep book math 5733 reading 5713 writing 5723 7th edition made by test prep books experts for

[practice test for praxis 5856 lcod clozemaker com](#) - Jun 16 2023

web apr 23 2023 practice test for praxis 5856 this is likewise one of the factors by obtaining the soft documents of this practice test for praxis 5856 by online you might not require more times to spend to go to the books introduction as well as search for them in some cases you likewise get not discover the notice practice test for praxis 5856 that

[practice test for praxis 5856 pdf free algoritmi pybossa](#) - Aug 06 2022

web organize study practice for real create the closest experience to test day conditions with two full length practice tests chart your progress with full and detailed explanations of all answers boost confidence with test taking strategies and experienced advice get to the head of the class

[0285625856 wer ruft an werruft info](#) - Apr 02 2022

web rufnummer phone 0285625856 was ist das für eine nummer anzahl der bewertungen 15 meinung der mehrheit verwirrend 49285625856

**practice test for praxis 5856 login machung ac id** - Sep 07 2022

web as this practice test for praxis 5856 it ends stirring living thing one of the favored books practice test for praxis 5856 collections that we have this is why you remain in the best website to see the unbelievable book to have practice test for praxis 5856 2020 05 31 barker mason health and physical education content knowledge practice

**praxis health and physical education 5856 5856 practice tests** - Sep 19 2023

web we offer 20 online practice exams with 2 400 unique questions our world class practice certification tests are designed to give you the knowledge you need to pass your praxis hea

*8 sınıf meb yayınları türkçe ders kitabı sayfa 52 56 57 58 59* - Jan 31 2022

web videolu Çözüm tıkla abone ol 8 sınıf meb yayınları türkçe ders kitabı sayfa 52 56 57 58 59 cevapları ile ilgili aşağıda bulunan emojileri kullanarak duygularınızı belirtebilir aynı zamanda sosyal medyada paylaşarak bizlere

practice tests for praxis ii 5856 book willowwoodco com - May 15 2023

web feb 26 2023 praxis ii speech language pathology practice questions are the simplest way to prepare for the praxis ii speech language pathology test practice is an essential part of preparing for a test and improving a test taker s chance of success the best way to practice taking a test is by going through lots of practice test questions our praxis ii

ГДЗ упражнение 528 русский язык 6 класс Ладыженская - Mar 01 2022

web Издательство Просвещение 2015 2023 Тип книги Учебник Часть 1 2 Добавить в избранное Подробное решение упражнение 528 по русскому языку для учащихся 6 класса авторов Ладыженская Баранов

758 n 2456th ave ursa il 62376 zillow - May 03 2022

web 758 n 2456th ave ursa il 62376 is currently not for sale the sqft single family home is a beds baths property this home was built in null and last sold on 2012 03 08 for 1 000 view more property details sales history and zestimate data on zillow

*practice tests for praxis ii 5856 download only* - Mar 13 2023

web practice tests for praxis ii 5856 downloaded from portal dlc ui edu ng by guest giovanny warren praxis ii elementary education multiple subjects 5001 exam secrets study guide praxis ii test review for the praxis ii subject assessments cirrus test prep includes practice test questions praxis ii technology

**practice test for praxis 5856 pdf georgiacollegesurvey gcsu** - Jul 05 2022

web remained in right site to start getting this info get the practice test for praxis 5856 member that we find the money for here and check out the link practice test for praxis 5856 logisticsweek combookmark file pdf practice test for praxis 5856

practice test for praxis 5856 when people should go to the

**practice tests for praxis ii 5856 pdf** - Apr 14 2023

web practice tests for praxis ii 5856 speech language pathology praxis exam dec 19 2022 web the speech language pathology praxis exam is owned and administered by ets as part of the praxis ii subject assessments however asha s council for clinical certification in audiology and speech language pathology cfcc appoints

practice tests for praxis ii 5856 download only - Nov 09 2022

web for practice tests for praxis ii 5856 and numerous book collections from fictions to scientific research in any way among

them is this practice tests for praxis ii 5856 that can be your partner practice tests for praxis ii 5856 downloaded from headandneckcancerguide.org by guest jazlyn ross praxis ii pennsylvania

**practice test for praxis 5856 donner medair.org** - Jan 11 2023

web for praxis 5856 practice test for praxis 5856 praxis ii health and physical education content knowledge 0856 exam secrets optical shop testing praxis ii health page 1 51 where to download practice test for praxis 5856 education 5551 exam secrets study guide praxis ii test review for the praxis ii subject assessments

**practice test for praxis 5856** - Dec 10 2022

web practice test for praxis 5856 practice test for praxis 5856 practice test for praxis 5856 dkneuro.com praxis ii health and physical education content knowledge health and physical education content knowledge practice test for praxis 5856 blacklist no practice test for praxis 5856 free ebooks download dewa

[apply for supplemental nutrition assistance program snap iowa.gov](#) - Aug 03 2023

web the supplemental nutrition assistance program snap provides benefits to supplement the food budget of income eligible families so they can purchase healthy food and move towards self sufficiency you can apply for snap benefits in three ways online paper application or over the phone

*iowa department of human services the emergency food assistance* - Dec 27 2022

web the emergency food assistance program tefap eligibility the table below shows eligible gross income guidelines before taxes per family size if your household income is at or below the income listed for the number of people in your household you are eligible

*f 1 food assistance program state summary december 2020 iowa* - Nov 25 2022

web the food assistance monthly participation report f 1 is a monthly summary of food assistance program participation statewide and for each iowa county it contains data starting with july 2016 breakouts are reported based on whether one or more members received some other form of help from the department of human services or only

[public benefits dubuque ia official website](#) - Jul 22 2022

web food assistance supplemental nutrition assistance program snap or food stamps women infants and children wic housing urban development hud subsidized housing section 8 veterans benefits need based federal student financial aid such as [supplemental nutrition assistance program snap iowa department](#) - Oct 05 2023

web the supplemental nutrition assistance program snap provides nutrition benefits to supplement the food budget of needy families so they can purchase healthy food and move towards self sufficiency to see if you are eligible for

**hhs services portal new location iowa** - Jan 28 2023

web services portal the iowa dhs services portal has a new name and location click the button below to go to the new site or

navigate there on your own the new site name is iowa hhs services portal and the location is hhsservices iowa gov  
*snap eligibility iowa department of health and human services - Sep 04 2023*

web iowa department of human services division of field operations 1305 e walnut st des moines ia 50319 or email your concern to myfoodassistance dhs state ia us note there have been reports of ads offering assistance for filling out snap applications

470 0462 food and financial support application iowa department - Oct 25 2022

web food and financial support application this form is to apply for supplemental nutrition assistance program snap family investment program fip or refugee cash assistance rca if you would prefer to complete an online application please visit hhs iowa gov anyone may fill out an application

*iowa supplemental nutrition assistance program snap - Jun 01 2023*

web the united states department of agriculture s usda supplemental nutrition assistance program snap provides food benefits access to a healthy diet and education on food preparation and nutrition to low income households

snap neifb - Feb 26 2023

web 1 855 944 food 3663 please be advised of upcoming holiday closures for the snap hotline winter holiday fri 12 23 mon 12 26 new years fri 12 30 closing at 12pm mon 1 2 apply online complete this form to be contacted by our snap outreach staff for application assistance we respect your privacy all submissions are confidential

*home iowa department of health and human services - Apr 18 2022*

web assistance programs food assistance snap wic child care assistance families providers cash assistance state supplementary assistance job training rent reimbursement family services child welfare families contractors reports advisory groups child care families providers reports child support families employers

**iowa department of human services food and nutrition service** - Mar 30 2023

web child and adult care food program commodity supplemental food program disaster assistance farm to school farmers market nutrition program food distribution program on indian reservations food safety fresh fruit and vegetable program nap block grants national school lunch program school breakfast program seniors farmers

*social services johnson county iowa - Mar 18 2022*

web for iowa department of health human services call 1 888 338 6067 for food assistance child care assistance fip and medicaid to report child or dependent adult abuse call 1 800 362 2178 child care wage enhancement program

iowa food assistance helping americans find help - Feb 14 2022

web how to apply for food assistance benefits in iowa to apply for iowa food assistance benefits contact your local dhs office print the dhs financial support application or use the online service at their website you can also call toll free 1 877 dhs 5678

to find out where your local iowa department of human services office is located

**hhs to issue summer 2023 p ebt food benefits to eligible iowa** - May 20 2022

web sep 18 2023 the iowa department of health and human services hhs and the iowa department of education have received approval from the united states department of agriculture food and nutrition service to issue summer 2023 pandemic electronic benefits transfer p ebt for eligible school age iowa children for the 2022 2023 school

**emergency food assistance iowa department of health and human services** - Jul 02 2023

web emergency food assistance the emergency food assistance program tefap provides food and meals at no cost through participating food pantries and meal sites the types of foods available varies based on availability and may include beans canned dried dairy milk cheese fresh eggs fresh

**iowa dhs announces increases to snap benefits in october** - Sep 23 2022

web oct 5 2021 advertisement the changes will happen automatically and recipients will see the increased benefits on their ebt cards in october for more information about department of human services food assistance programs including how to apply for benefits visit dhs iowa gov food assistance

**iowa legal aid** - Jun 20 2022

web jul 21 2023 the new yorker mobile homes victory des moines register recovering 180 000 for couple cheated out of their home authored by iowa department of health and human services apply online for food assistance cash assistance fip child care assistance medical assistance well child and prenatal care

*request help with snap iowa food bank association* - Apr 30 2023

web through the iowa department of human services low income iowans can apply for snap if approved for these benefits recipients may use an ebt card to purchase food at retail stores applications are fast and can be completed online or over the phone at 855 944 food 3663

**department of human services scott county iowa** - Aug 23 2022

web 600 w 4th street davenport iowa 52801 563 326 8680 iowa department of human services dhs the department of human services is a comprehensive human service agency coordinating paying for and or providing a broad range of services to some of iowa s most vulnerable citizens